

Instruction sheet for BA201 Communications Isolator

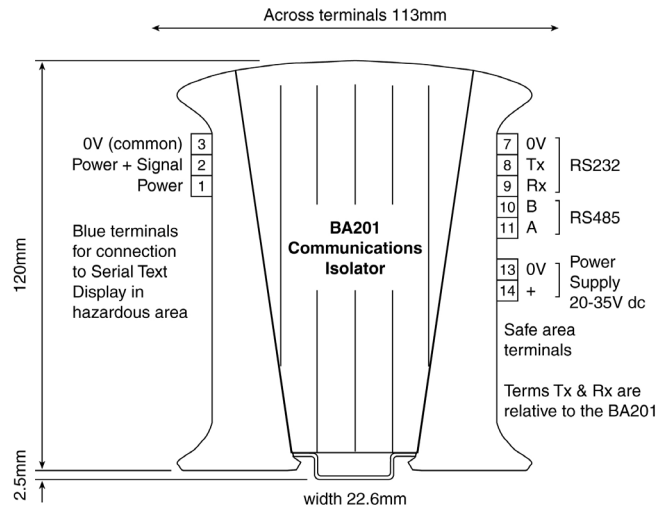
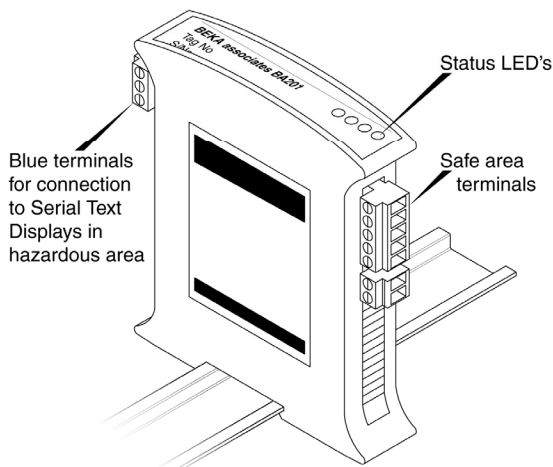

Fig 1 BA201 dimensions and terminal numbers

The BA201 Communications Isolator is CE marked to show compliance with the European Explosive Atmospheres Directive 94/9/EC and the European EMC Directive 89/336/EEC

1. INTRODUCTION

These instructions describe the function, certification, installation, safe use and maintenance of the BEKA BA201 Communications Isolator. This isolator is primarily intended for communicating with and powering BEKA intrinsically safe Serial Text Displays, but may be used with other intrinsically safe hazardous area equipment having suitable intrinsic safety parameters.

2. DESCRIPTION

The BA201 Communications Isolator is a dedicated interface for connecting intrinsically safe BEKA Serial Text Displays, such as the BA484D and the BA488C, to a safe area computer system. It is certified as intrinsically safe *associated apparatus* and must be installed in a non-hazardous safe area. The BA201 provides intrinsically safe galvanic isolation between the safe and hazardous areas, plus conversion of RS232 or RS485 serial data to the dedicated 2 or 3-wire communications signaling required by BEKA Serial Text Displays.

The BA201 Communications Isolator also powers the Serial Text Display and, depending upon the wiring configuration, up to four displays may be connected to each BA201 Isolator. To prevent earth loops both communications ports are functionally isolated from the BA201 power supply allowing an earthed or floating supply to be used.

3. CERTIFICATION

The BA201 Communications Isolator has the following intrinsic safety *associated apparatus* certifications that permit installation throughout the world:

ATEX	ITS07ATEX25602
IECEX	IECEX ITS 07.0014
FM	3610 Entity & 3611 Nonincendive File number 3029711
cFM	Entity & Nonincendive File number 3029711C

The ATEX and IECEX certifications and installations, which comply with the same standards, are described in the main section of this instruction sheet. For installations in the USA and Canada, see section 11.

3.1 ATEX certification

Notified Body Intertek Testing & Certification Ltd have issued the BA201 Communication Isolator with an EC-Type Examination Certificate ITS07ATEX25602. This confirms compliance with the European ATEX Directive 94/9/EC for [Ex ia] IIC *associated apparatus*. The Communications Isolator carries the Community Mark and subject to local codes of practice, may be installed in any of the EEA member countries. This instruction sheet describes installations which conform to BS EN60079:Part14 Electrical Installation in Hazardous Areas. When designing systems for installation outside the UK, the local Code of Practice should be consulted. Fig 2 shows the certification information label that is on the side of the BA201 isolator.

3.2 IECEX certification

IECEX is a global certification scheme for explosion protected products which aims to harmonise international certification standards. For additional information about the scheme and to view the BEKA associates certificates please visit www.iecex.com. The BA201 Communication Isolator has been issued with an IECEX certificate IECEX ITS 07 0014 by Intertek Testing & Certification Ltd. The safety parameters, standards and installation requirements are the same as for the ATEX certification, however when designing systems for installation outside the UK, the local Code of Practice should be consulted.



Fig 2 Certification information label

3.3 Safety parameters

The ATEX and IECEx certifications specify the following intrinsic safety output parameters:

Terminals 1 wrt 3	
Uo	= 21.2Vdc
Io	= 96mA
Po	= 0.51W
Co	= 183nF
Lo	= 3.2mH

Terminals 2 wrt 3	
Uo	= 13.7Vdc
Io	= 84mA
Po	= 0.45W
Co	= 0.78µF
Lo	= 4.1mH

4. INSTALLATION

The BA201 should only be installed by trained competent personnel.

4.1 Location

The BA201 Communications Isolator is certified as *associated apparatus* and may only be installed in a safe area where it will not be exposed to flammable gases or combustible dusts. Additional protection is required if the installation is damp or susceptible to impact. If the Communications Isolator is required in a hazardous area it must be protected by a flameproof, pressurised or purged enclosure. Although certified for uses between -40 and +70°C, the guaranteed operating temperature range is -20 to +60°C.

4.2 Mounting

The isolator is DIN rail mounting and may be clipped to any low or high profile 35mm wide 'top hat' rail complying with DIN46277, EN50022 or BS5584. Horizontal or vertical rail may be used, but if the ambient temperature is likely to exceed 30°C a horizontal rail is recommended. A gap of at least 2mm should be left between adjacent BA201 isolators increasing to 5mm if the ambient temperature is likely to exceed 30°C.

Wiring to the hazardous area from the BA201 blue terminals should be segregated from all safe area wiring as specified in EN 60079-14.

To remove a BA201 isolator from the DIN rail, use a screwdriver to gently slide the red securing clip outwards as shown in Fig 3.

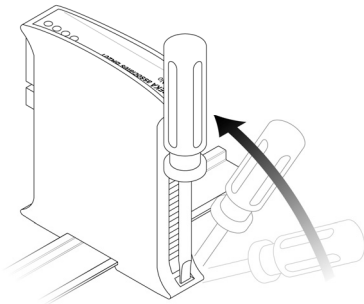

Fig 3 Removing BA201 from the DIN rail

5. ELECTRICAL SYSTEM DESIGN

The BA201 is primarily designed for powering and communicating with BEKA intrinsically safe Serial Text Displays such as the BA484D and BA488C, but it may be used with other certified hazardous apparatus with compatible entity parameters.

These instructions should be read in conjunction with those for the BEKA Serial Text Display which define the connections between the isolator and the Serial Text Display(s) for 2 and 3-wire systems.

5.1 Power supply

The BA201 Communications Isolator requires a 20 to 35V dc supply. The isolator power supply terminals are electrically isolated from the serial communications terminals allowing an earthed or floating supply to be used. The current drawn depends upon the number of Serial Text Displays connected to the isolator.

No of Serial Text Displays	Display Brilliance	Typical current
1	Full	70mA
1	Half	55mA
2	Full	100mA
3	Half	85mA
4	Half	100mA

TR Automatyka Sp. z o. o.
ul. Lechicka 14 ; 02-156 Warszawa

Tel. (+48 022) 886 10 16
Fax. (+48 022) 846 50 37

5.2 Serial communication

The BA201 Communications Isolator has an RS232 and an RS485 safe area port, but only one of them may be used at a time. No configuration is required, it is only necessary to connect to the required port, the isolator will automatically function at any of the Serial Text Display communication rates between 300 and 19.2k baud. The unused port should be left unconnected. Four green LEDs on the top of the BA201 indicate the isolator's status as shown in Fig 4.

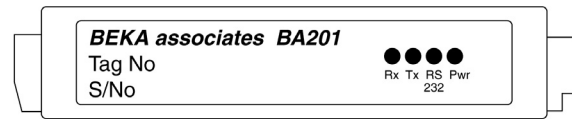

LED	FUNCTION
Pwr	Power supply
RS232	RS232 serial communication functioning
Tx	Serial communication being transmitted by isolator
Rx	Serial communication being received by the isolator (Does not imply that the message is valid)

Fig 4 LED status indicators

6. ACCESSORIES

6.1 Tag number

BA201 isolators can be supplied identified by a tag number thermally printed onto the label adjacent to the status LEDs protected by a hinged transparent window. Alternatively a tag number may be added on-site using a self-adhesive label.

7. ROUTINE MAINTENANCE

The mechanical condition of the isolator and terminations should be regularly checked. Initially annual inspections are recommended, although the inspection frequency should be adjusted to suit the environmental conditions.

8. SERVICING

No attempt should be made to repair a faulty BA201 Communications Isolator. Suspect isolators should be returned to BEKA associates or our local agent for repair.

9. GUARANTEE

Communication Isolators which fail within the guarantee period should be returned to BEKA associates or our local agent. It is helpful if a brief description of the fault symptoms is provided.

10. CUSTOMER COMMENTS

BEKA associates is always pleased to receive comments from customers about our products and services. All communications are acknowledged and whenever possible, suggestions are implemented.

11. INSTALLATION IN THE USA & CANADA

The BA201 has intrinsic safety and nonincendive FM & cFM Approval allowing installation in the USA and Canada.

BA201 installations must comply with the BEKA associates Control Drawing CI201-11, ANSI/ISA RP12.06.01 and the National Electrical Code ANSI/NFPA70 in the USA and with C22.2 in Canada.

The FM Control Drawing may be downloaded from the BEKA web site, or requested from the BEKA sales office or from our US agent:

Exloc Instruments Inc
PO Box 861406
Warrenton
VA 20187
USA
Tel: 540 428 3088
Fax: 540 428 3028
e-mail: info@exloc.com

www.trautomatyka.pl
biuro@trautomatyka.pl

