

Instruction Manual For Advisor A85

Temperature
Digital Panel Meter (Thermocouple Input)

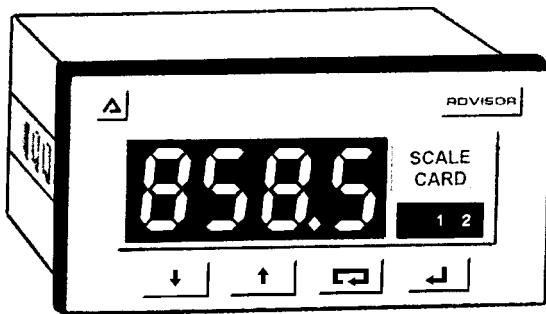

Features

- Thermocouple input (E,J,K,N,R,T and Pallaplat)
- °C or °F
- 4 Digit Display
- Adjustable Brightness
- 24Vdc, 115Vac & 230Vac Models
- High Accuracy
- Reliable
- Maximum and Minimum Hold
- IP65 Front
- Easy Clean Membrane Buttons
- Button Disable Function (Anti-tamper)
- Password Protection
- Plain Language Programming Menus
- Optional Dual Alarm Relays, Latching or Non-Latching, High or Low, Delays and Acknowledgement (Changeover 5A rated)
- Optional 4-20mA Analogue Output

Contents

- 1) Unpacking
- 2) Safety and Warnings
- 3) Introduction
- 4) Electrical Specification
- 5) Dimensions
- 6) Installation
- 7) Electrical Connections
- 8) Setting Up
 - 8.1) General
 - 8.2) Button Functions – In Programming Mode
 - 8.3) General Programming Structure
 - 8.4) Main Programming Menu Flowchart
 - 8.5) Sub Menu Programming
 - 8.5.1) Input Selection
 - 8.5.2) 4-20mA Analogue Output
 - 8.5.3) Setting Internal References
 - 8.5.4) Max and Min Hold
 - 8.5.5) Front Panel Controls
 - 8.5.6) Alarm Setpoint Parameters
 - 8.6) The Alarm Parameters
 - 8.6.1) Hysteresis
 - 8.6.2) Enable
 - 8.6.3) Setpoint 1(or Setpoint 2)
 - 8.6.4) High/Low
 - 8.6.5) Normally Energised
 - 8.6.6) Delay
 - 8.6.7) Silence
 - 8.6.8) Access Setpoints
 - 8.6.9) Latch
 - 8.7) Pushbutton Re-enable
 - 8.8) Burn Out Drive
- 9) General Operation
 - 9.1) Button Functions – In Normal Display Mode
 - 9.1.1) Gaining Access to the Alarm Setpoints
 - 9.1.2) Resetting the Max/Min Register.
 - 9.1.3) Display Brightness
 - 9.1.4) Unlatching Alarms and Alarm Silencing
 - 9.1.5) Calibration Using The “Trim” Menu
- 10) Troubleshooting

1) Unpacking

The packaging for your Advisor A85 includes:

- 1) An Advisor A85 temperature digital panel meter
- 2) A pair of panel mounting clips
- 3) A neoprene sealing gasket
- 4) Full set of connector blocks
- 5) Spare °C and °F self-adhesive labels
- 6) This instruction manual

Check your unit against the above parts list to make sure that nothing has been lost or damaged in transit. Keep the packing box as this will be useful if in the unlikely event you need to return the Advisor. If any parts are missing or damaged, please contact your supplier.

2) Safety and Warnings

The Advisor A85 has been designed and tested in accordance with the EU directive (73/23/EEC) for Low Voltage (LVD) apparatus and the EU Directive (89/336/EEC) for Electromagnetic Compatibility (EMC). Copies of the certificate of compliance and test reports are available on request.

It should be noted that the instrument is a panel mounted meter and after installation only the front panel is intended for general operator access. Installation must be completed by authorised and qualified personnel.

To ensure safe operation/installation the following warnings must be observed.

- **Before installing the meter, ensure the marked**



CAUTION:
Risk of electric shock



CAUTION:
Read instructions prior to installation and operation.

rated voltage agrees with the actual power supply voltage.

- **A safety earth must be connected to a conductive panel into which the meter will be installed. A safety earth must be connected with the AC mains supply to the instrument.** (If applicable)
- **Do not expose the rear of the meter to rain or condensing humidity.**
- **Do not use the meter in a flammable or explosive atmosphere.**

3) Introduction

The Advisor A85 digital panel meter is one of a family of Advisor panel meters. The A85 has been designed specifically to display temperature in °C or °F. It is a microprocessor based instrument and consequently simple to use. The Advisor A85 will accept any one of 7 different thermocouple inputs – E,J,K,N,R,T or Pallaplat

The power supply is selected at the time of ordering. Each Advisor has a display brightness control and max & min hold already included in the internal software.

An Advisor A85 can also be fitted with dual alarms (changeover relay contacts) and an analogue output (4-20mA).

Advisors have been designed to be reliable in harsh environments. The front is rated with an ingress protection of IP65 and rear of IP20. The programming buttons on the front of the Advisors are sealed membrane type allowing the unit to be kept clean by hosing or wiping down.

4) Electrical Specification

Power Supply

10 to 35Vdc
99 to 132Vac 50/60Hz or
198 to 264Vac 50/60Hz

Power Consumption

4W Max.

Input Type

E,J,K,N,R,T or Pallaplat (User selectable).

Resolution

0.1° or 1°

Type	Display Range (0.1° resolution)	Display Range (1° resolution)	Resolution (°C) between 25 and 75 % of span.
E	-199.9 to 999.9	-270 to 1000	0.2
J	-199.9 to 999.9	-210 to 1200	0.2
K	-199.9 to 999.9	-270 to 1372	0.3
N	-199.9 to 999.9	-270 to 1300	0.3
R	-48.3 to 999.9	-48 to 1767	1.0
T	-199.9 to 400.0	-270 to 400	0.2
Pallaplat	-100.0 to 490.0	-100 to 490	0.3

Accuracy

Including non-linearity at 20°C +/-0.1% of span +/- ½ digit

Isolation

500Vrms between input, power supply and any optional accessory outputs.

Accessories (factory fitted)

Alarms (Dual)

Single pole changeover relay contact, 250V @ 5A ac and 30V @ 5A dc.

Analogue Output (4-20mA)

500 Ohms maximum load.

5) Dimensions

Recommended panel cut-out: (dimensions in mm)

DIN43 700. 92.0+0.8/-0.0 x 45+0.6/-0.0

To achieve an IP65 seal between the instrument and the panel

90.0+0.5/-0.0 x 43.5+0.5/-0.0

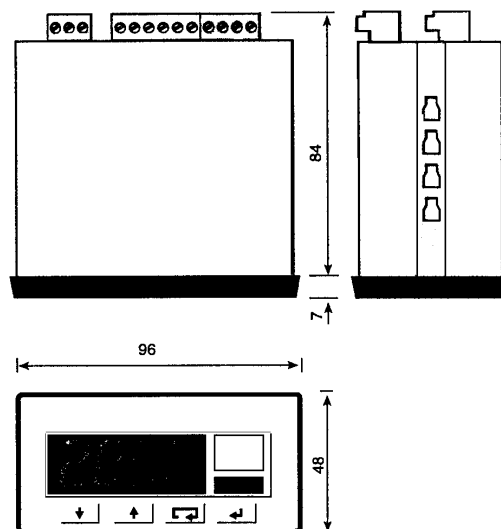

6) Installation

The installation procedure is as follows:

- Insert the instrument into the panel opening from the front.
- Fix the two panel mounting clips to opposite sides of the instrument and tighten until the instrument is secure.
- Connect the panel wiring to the rear terminal blocks.

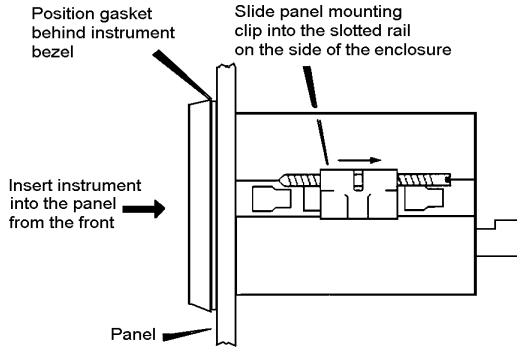

7) Electrical Connections

All connections to the instrument are made using high quality two part PCB connectors with screw clamp terminals (which accept cables between 0.5 and 1.5mm² in diameter).

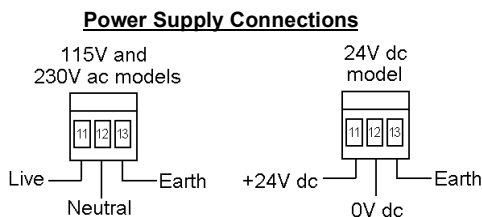
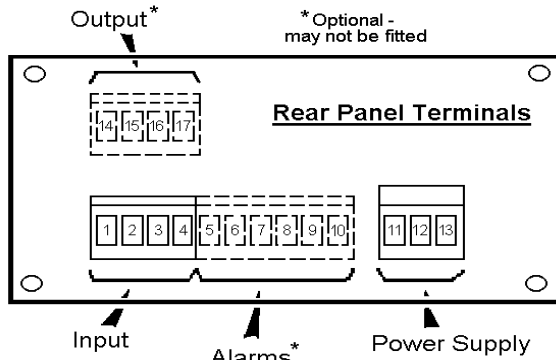

Signal Input and Alarm Terminals (If Fitted)

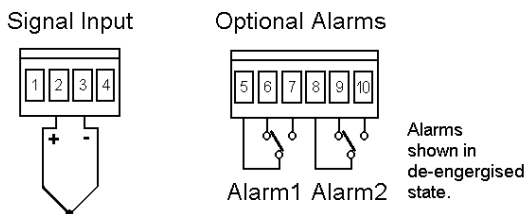

NOTE: Alarm terminals may carry up to 240Vac!

Analogue Output Terminals (If Fitted)

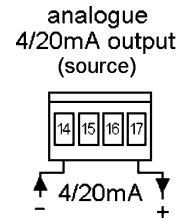

8) Setting Up

8.1 General

Advisors are calibrated prior to delivery. If calibration needs to be performed at a later date, follow the procedures in section 8.5.3 or 9.1.5. Advisor panel meters are set up using the four front panel pushbuttons. Parameters are accessed using a plain language menu which can be protected by a user programmable password.

It is possible to disable the pushbuttons to stop any tampering by unauthorized personnel. If the anti-tamper pushbutton disable function has been switched on, you will need to regain "local" control by following the key press sequence as outlined in section 8.7

8.2 Button Functions – In Programming Mode

To enter Programming Mode, press the scroll and return buttons together.



When the instrument is supplied, the security access password is set to "0000". If this password has not been changed, then the operator is given immediate access to the programming mode. If the password has been changed, then the operator will need to enter the new password before being able to access programming mode. (If the password has been forgotten – see section 8.5.5)

In Programming Mode, the pushbuttons have the following functions:

- Decreases a setting/variable or moves to the previous menu option. This button is referred to as the "down button"
- Increases a setting/variable or moves to the next menu option. This button is referred to as the "up button"
- Select a menu option or "scroll into" the next menu option. This button is referred to as the "scroll button".
- Confirm variable selection or return to previous menu option or exit programming mode. This button is referred to as the "return button".

8.3) General Programming Structure

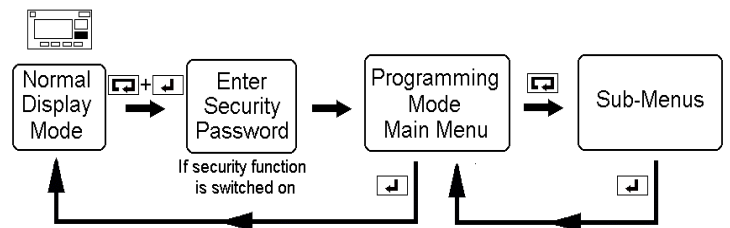

The above flow chart gives a general overview of the programming structure for an Advisor. The key point to remember is that if you ever get lost or unsure of what function you are programming, keep pressing the return button and eventually you will get back to the Normal Display Mode.

8.4) Main Programming Menu Flowchart

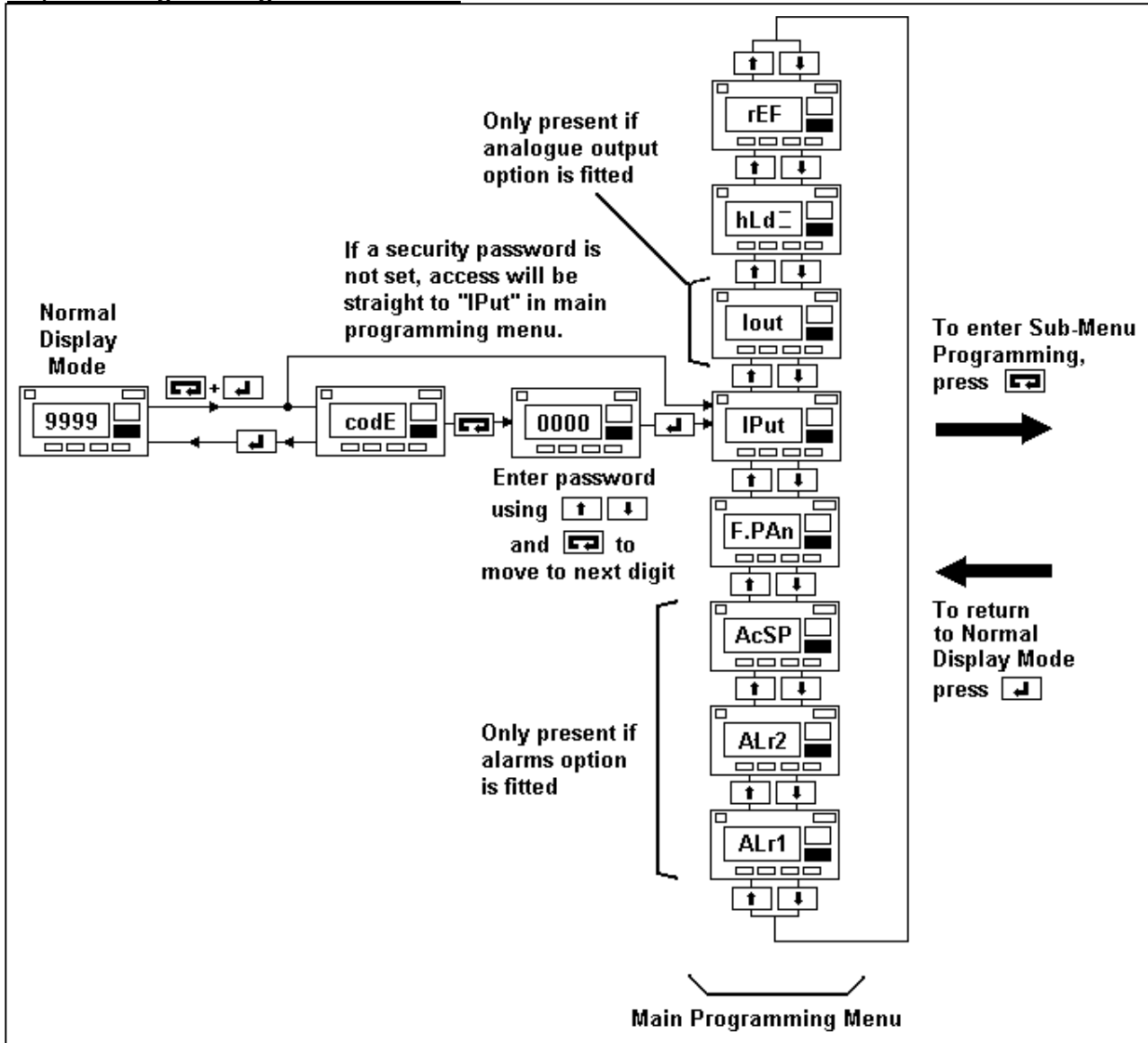

8.5) Sub-Menu Programming

The "Sub-Menu" Programming allows the operator to enter the variables and functions required.

This function allows the setting of the input type, the units of display ($^{\circ}\text{C}$ or $^{\circ}\text{F}$), the display resolution and the cold junction compensation.

8.5.1) "IPut" – Input Selection

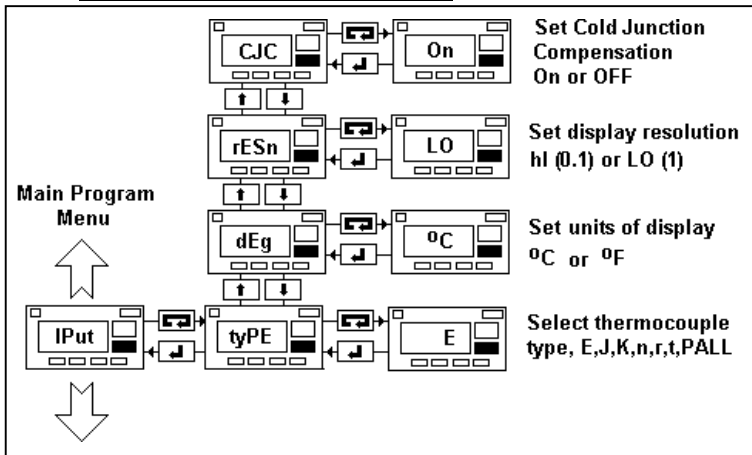

8.5.2) "lout" – Analogue Output (4-20mA) (if fitted)

This parameter sets the display values between which the analogue output operates. To set the actual analogue output current see section 8.5.3.

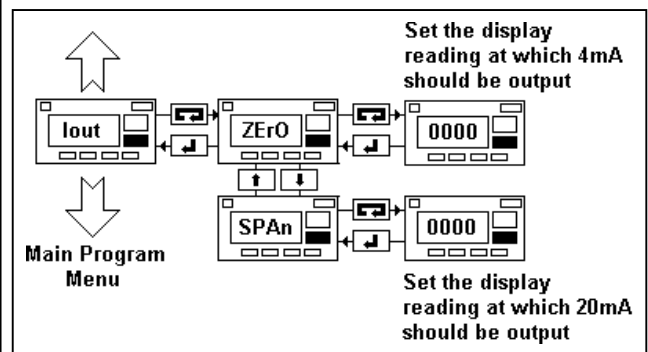

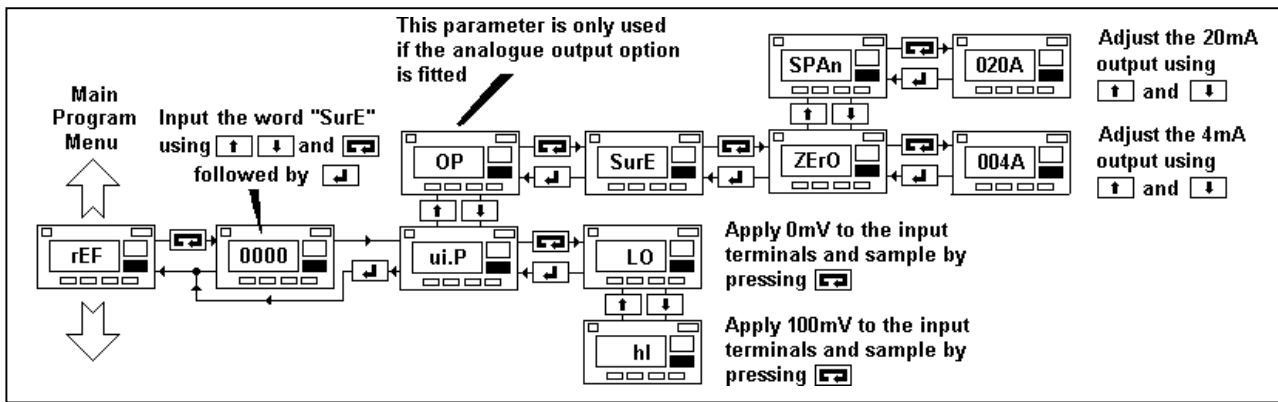

8.5.3) "rEF" – Setting Internal References

This parameter is used to set the internal references. An Advisor can be calibrated by using the "rEF" sub-menu or the "trim" function (see section 9.1.5). The "rEF" sub-menu also allows the fine adjustment of the analogue output current (if fitted). **NOTE** If adjusting the 4-20mA output signal, ensure there is no external equipment connected that may be adversely affected. You will need a digital multimeter to monitor the adjustment of the 4-20mA analogue output.

8.5.4) "hLd" - Max and Min Hold. Whether this parameter is set to "On" or "OFF", the maximum and minimum temperatures are always being monitored and updated. In

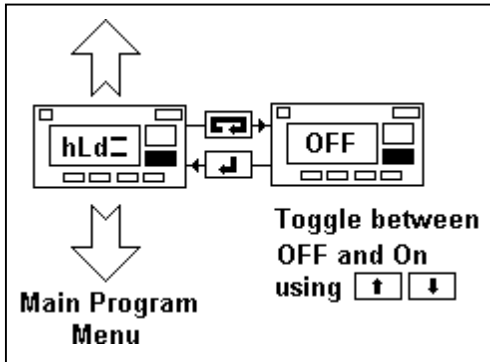

Normal Display Mode with this parameter set to "On", the maximum and minimum temperatures can be displayed (by pressing the up and down buttons) and reset (by pressing up and down buttons together). The maximum and minimum temperatures will be lost if there is a power failure.

8.5.5) "F.PAn" – Front Panel Controls (password entry and pushbutton disable)

The front panel controls ("F.PAn" parameters) allow a security access password to be set or altered and allow the pushbuttons to be enabled or disabled. If the "bttN" parameter is "on", then the pushbuttons will function normally, if the "bttN"

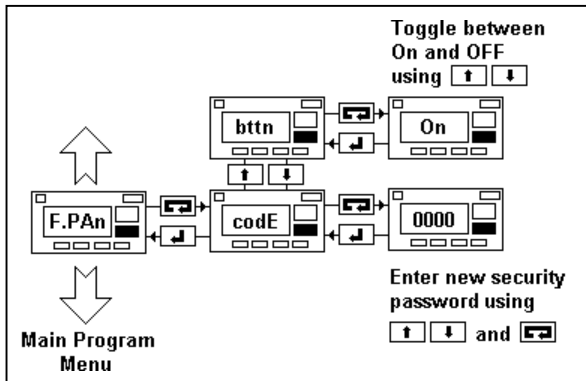

parameter is set to "off" then the pushbuttons will be disabled (to re-enable see section 8.7). The security password set in "CodE" is the password required to gain access to the Programming Mode. If password controlled access is not needed, the code should be set to "0000" (four zeroes).

If a password is forgotten, then the emergency access code "FPac" ("Forgotten Panel Access Code") will provide access to programming mode, thereby allowing the present password to be read or a new password to be entered.

8.5.6) "ALr1" and "ALr2" – Alarm Setpoint Parameters (if fitted).

See Section 8.6) for a full description of alarms and alarm setting-up.

8.6) The Alarm Parameters.

Alarms (1 & 2) have the same set-up parameters, but operate independently of each other. Each can be set as a high or low alarm.

8.6.1) "hStr" - Hysteresis. On an Advisor, hysteresis is set in engineering units and can be set to any value. Hysteresis can be used to stop alarm "chatter" as the diagram shows.

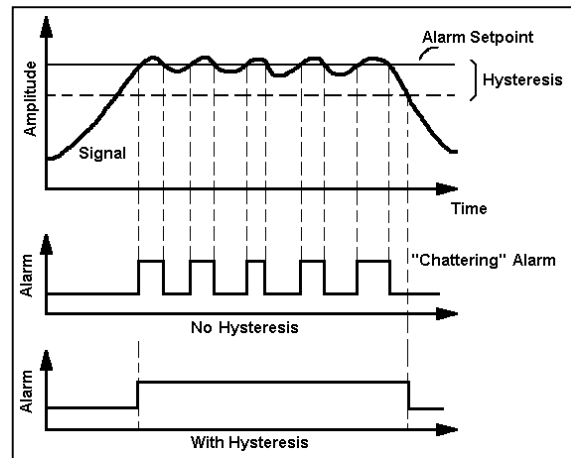

8.6.2) "EnbL" – Enable. This parameter enables an alarm to be easily switched on or off without having to change all the other alarm parameters. **NOTE:** If the alarms are not enabled, the alarm relays will stay in the position determined by the "nE" (normally energized) parameter.

8.6.3) "SP1" - Setpoint 1. (or setpoint 2). This is the alarm setpoint value and is entered in the same units as the display.

8.6.4) "hILO" - High/Low. Each alarm can be set as either active high or active low.

8.6.5) "nE" - Normally Energised. This parameter determines the state of the changeover relay. If "nE" is "on" then the alarm relay is normally energised i.e. an alarm state will cause the relay to be de-energized. If the alarm is normally energised, this will also produce a "failsafe" condition should there be a power failure.

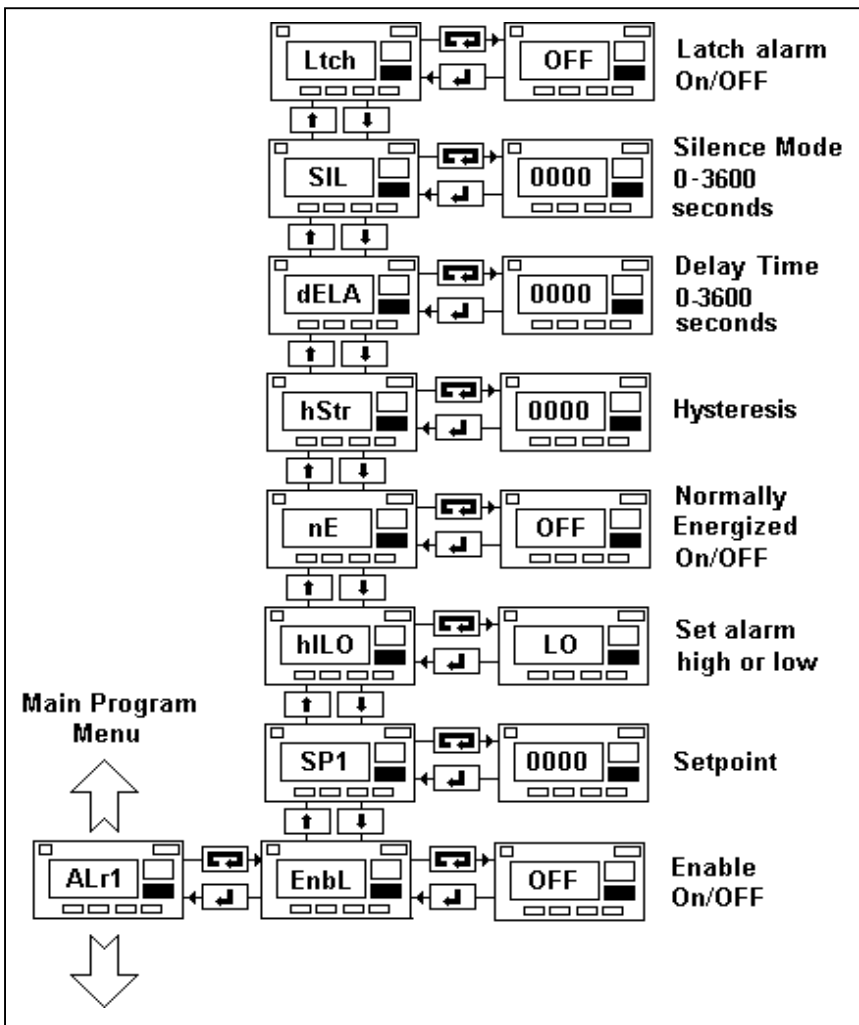

8.6.6) “dELA” - Delay. This function can be programmed to delay alarm activation by up to 3600 seconds. If set to “0000” then there is no delay in the alarm.

8.6.7) “SIL” – Silence. When in alarm mode, this function allows the relay outputs to be changed over for up to 3600 seconds. Hence, an alarm sounder connected to the output relays can be temporarily “silenced” by pressing the scroll button. If the input signal is still in the alarm range after the silence time has elapsed, the alarm is automatically re-activated.

8.6.8) “AcSP” - Access Setpoints. This option allows an operator direct access to the alarm setpoints from Normal Display Mode without having to go through all the other menus. When this function has been enabled, pressing the scroll and up button together will give direct access to the setpoints. Access can be limited by setting a password under the “Access Code” (“Ac.cd”) parameter.

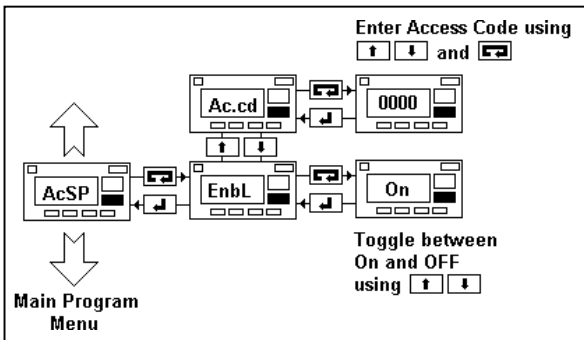

8.6.9) “Ltch” - Latch. This function allows the alarms to be latched on. If the input signal causes the alarm to trip and this function is “on”, the relay output(s) will be held in the alarm state even if the input signal falls back into the normal operating range. In Normal Display Mode, a latched alarm is acknowledged (released) by pressing the scroll button.

8.7) Pushbutton Re-enable

The pushbutton disable function or anti-tamper function (see section 8.5.5) allows the pushbuttons to be disabled - ideal if the Advisor could be open to tampering from unauthorized personnel. Once this function has been switched on, the only way to regain control of the pushbuttons is to push the buttons in the following sequence.

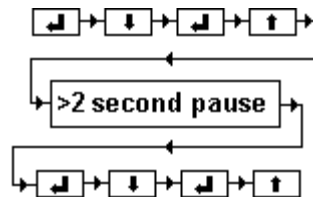

Once this sequence has been followed, the display will briefly show “good” and the buttons will be re-enabled.

8.8) Burn Out Drive

An Advisor A85 can detect when a thermocouple has broken, or become disconnected from the input. It is possible to configure the A85 to drive the display either to the top or bottom end of its display range. If the burn out drive is set to off, the display will drift around 0°C. To set the burn-out drive, a link inside the unit should be positioned as shown in the diagram. To adjust the burn out drive - disconnect all inputs and remove the four rear panel fixing screws. Carefully slide the electronic board sets half way out of the case. Do not remove the rear panel cover from the circuit boards – the links are accessible from the side. Position the link as required and carefully re-assemble.

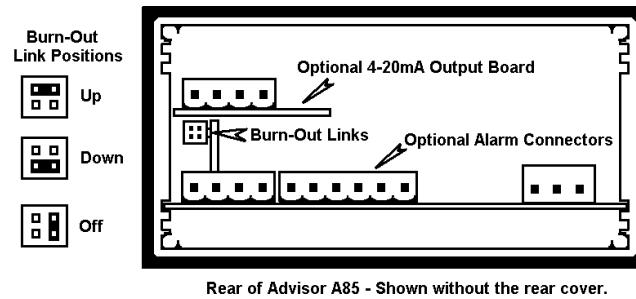

9) General Operation

9.1 Button Functions – In Normal Display Mode

 Pressing this button causes the display to show one of the following parameters. Listed in order of priority they are as follows.

- The minimum recorded temperature held by the max/min hold register (if enabled).
- The display at which 4mA is re-transmitted on the analogue output (if fitted).
- The lowest temperature reading possible with the selected thermocouple.

After 5 seconds of pressing and holding the down button, the display brightness will be reduced.

 Pressing this button will cause the instrument to show one of the following parameters. Listed in order of priority they are as follows.

- The maximum recorded temperature in the max/min hold register (if enabled).
- The display at which 20mA is re-transmitted on the analogue output (if fitted).
- The highest temperature reading possible with the selected thermocouple.

After 5 seconds of pressing and holding the up button, the display brightness will be increased.



If alarms are fitted, this button will silence alarm outputs and acknowledge latched alarms (if these parameters have been switched "on" – see sections 8.6.7 and 8.6.9).



This button has no effect during Normal Display Mode.

9.1.1) Gaining access to the alarm setpoints.



+



It may be necessary for an operator to regularly change alarm setpoints. There is a quick access option to allow an operator access to the setpoints without having to go through all the other programming menus. This access method also prevents unauthorized access to the other programming menus. Press the scroll and up buttons together to gain access to the alarm setpoints (to switch this function on – see section 8.6.8). The operator will then be able to access the setpoints (SP1 and SP2) by pressing the up and down button. New setpoints can then be entered with the up, down and scroll buttons followed by the return button. A security access code can be programmed (see section 8.6.8) to verify authorized access to the setpoints.

9.1.2) Resetting the Max/Min Register.



+



If the "Hld" parameter has been set to "On" (section 8.5.4), pressing the up and down buttons together in Normal Display Mode will reset the stored max/min values to the present display reading.



9.1.3) Display brightness

It is possible to adjust the brightness of an Advisor at any time during normal operation. To increase the display brightness, press and hold the up button. After 5 seconds, all the segments on the display will light up and the brightness will steadily increase to its maximum. When the desired brightness is reached the button should be released. Likewise the brightness can be reduced by pressing and holding the down button. The display brightness is "remembered" if there is a power failure.

9.1.4) Unlatching alarms and alarm silencing (if fitted)

A latched alarm will be unlatched by pressing the scroll button (to set an alarm latch see section 8.6.9). The alarm will change state and the alarm LED annunciator will be extinguished. An alarm will also be silenced (or acknowledged) by pressing the scroll button (to enable alarm silencing see section 8.6.7). The alarm contacts will change state but the alarm LED annunciator will remain lit whilst the input signal is within the alarm range.

9.1.5 Calibration using the “trim” menu.

 +  The trim menu enables the Advisor to be calibrated to a known external reference. From Normal Display Mode, the trim menu is selected by pressing the scroll and down buttons together. If no security password is requested (“CodE” -see section 8.5.5) the first parameter “ZErO” will be displayed. By pressing the scroll button again the Advisor will display the reading corresponding to the current input. Set the input to a known reference and press the up or down button to “trim” the display to the corresponding reading. Pressing the return button will cause the Advisor to display this reading whenever it sees the same input. If the 4-20mA analogue output option is fitted, the up and down buttons will cause the 4mA output current to be trimmed – a multimeter needs to be connected to the analogue output. If the 4-20mA output does not need trimming, press the return button and the Advisor will again display “ZErO”

Follow the same procedure to set the upper temperature reading and 20mA output as shown in the diagram. To clear any trims, press the scroll button at the “CLr” option.

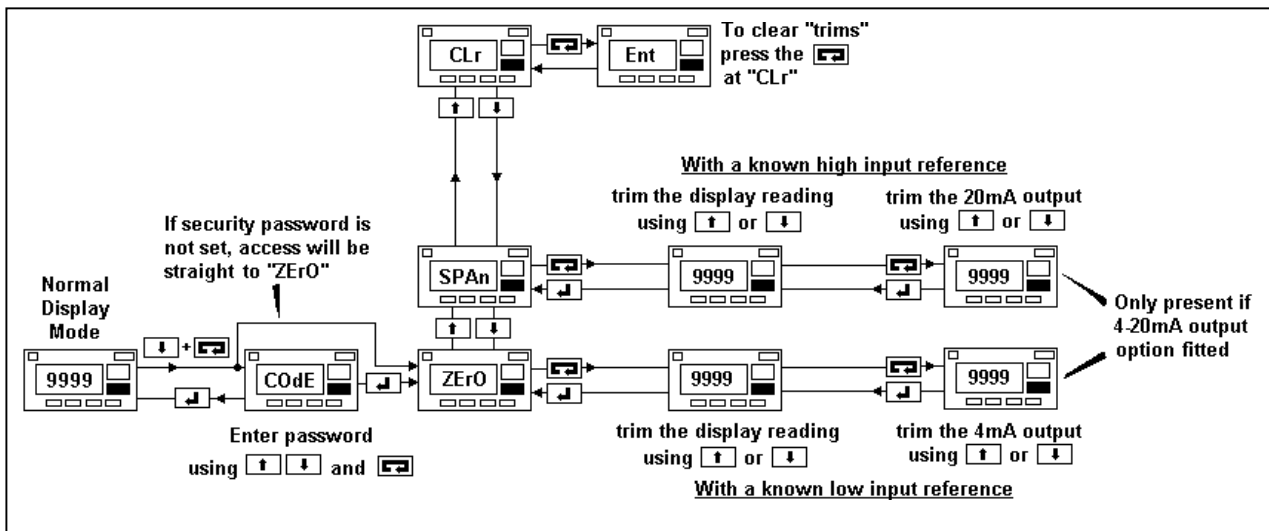

10) Troubleshooting

There is no display. Check all the connections are correctly made and check the power supply for the correct rating.

The display is not very bright/too bright. Adjust the brightness by pressing and holding the up or down button. (Section 9.1.3)

The display doesn't seem to be responding to a change of temperature. Check the thermocouple is correctly connected and functional.

None of the pushbuttons seem to be working. It may be that the pushbuttons have been disabled (i.e. anti-tamper function has been switched on). Enter the button re-enable sequence. (Section 8.7)

I've forgotten my password – how do I get access to programming mode? Enter “FPAc” at the password prompt (mnemonic “Forgotten Programme Access Code”) and in “F.PAn” menu option read existing password or enter a new one. (Section 8.5.5)

The alarms are on when they should be off and vice versa. Check the high and low alarm settings (Section 8.6.4) and/or check you have the normally energized (“nE”) parameter correctly programmed (Section 8.6.5)

The analogue output current doesn't seem to be correct. The analogue output can be adjusted. (Sections 8.5.2 and 8.5.3)

The display doesn't move from its maximum or minimum. The burn-out drive may have detected a faulty thermocouple. Alternatively, the thermocouple may also have become disconnected.