



INSTRUCTION MANUAL

SIL 3 Repeater Power Supply

Hart compatible

DIN-Rail Models D1014S, D1014D

D1014 Analog Input Repeater Power Supplies

Characteristics	3
Technical Data	3
Ordering Information	3
Terminal Block Connections	4
Parameters Table	5
Front Panel and Features	6
Function Diagram	6
Warning	8
Operation	8
Installation	9
Start-up	9
Configuration	10
Calibration instruction and Troubleshooting	12
Different power supply	14
Installation in Cabinet	15

Characteristics

General Description: The single and dual channel DIN Rail Repeater Power Supply, D1014S and D1014D is a high integrity analog input interface suitable for applications requiring SIL 3 level (according to IEC61508) in safety related system for high risk industries. Provides a fully floating dc supply for energizing conventional 2 wires 4-20 mA transmitters located in Hazardous Area, and repeats the current in floating circuit to drive a Safe Area load. The circuit allows bi-directional communication signals, for Hart transmitters.

Function: 1 or 2 totally independent and isolated channels I.S. analog input for 2 wires loop powered Hart transmitters, provides 3 port isolation (input/output/supply) and current (source or sink) or voltage output signal.

Signalling LED: Power supply indication (green).

Field Configurability: mA (source or sink) or V output signal.

Hart Communication Frequency Band: 0.5 to 2.5 KHz within 3 dB.

EMC: Fully compliant with CE marking applicable requirements.

Technical Data

Supply: 12-24 Vdc nom (10 to 30 Vdc) reverse polarity protected, ripple within voltage limits ≤ 5 Vpp.

Current consumption @ 24 V: 110 mA for 2 channels D1014D, 55 mA for 1 channel D1014S with 20 mA output typical.

Current consumption @ 12 V: 220 mA for 2 channels D1014D, 110 mA for 1 channel D1014S with 20 mA output typical.

Power dissipation: 1.8 W for 2 channels D1014D, 0.9 W for 1 channel D1014S with 24 V supply voltage and 20 mA output typical.

Max. power consumption: at 30 V supply voltage and short circuit condition, 3.4 W for 2 channels D1014D, 1.7 W for 1 channel D1014S.

Isolation (Test Voltage): I.S. In/Out 1.5 KV; I.S. In/Supply 1.5 KV; I.S. In/I.S. In 500 V; Out/Supply 500 V; Out/Out 500 V.

Input: 4 to 20 mA (2 wire Tx current limited at ≈ 25 mA).

Transmitter line voltage: ≥ 15.0 V at 20 mA with max. 20 mVrms ripple on 0.5 to 2.5 KHz frequency band.

Output: 4 to 20 mA, on max. 600 Ω load in source mode; V min. 5 V at 0 Ω load V max. 30 V in sink mode, current limited at ≈ 25 mA or 1 to 5 V on internal 250 Ω shunt (or 2 to 10 V on internal 500 Ω shunt on request).

Response time: 20 ms (10 to 90 % step change).

Output ripple: ≤ 20 mVrms on 250 Ω communication load on 0.5 to 2.5 KHz band.

Frequency response: 0.5 to 2.5 KHz bidirectional within 3 dB (Hart protocol).

Performance: Ref. Conditions 24 V supply, 250 Ω load, 23 ± 1 °C ambient temperature.

Calibration accuracy: $\leq \pm 0.1$ % of full scale.

Linearity error: $\leq \pm 0.1$ % of full scale.

Supply voltage influence: $\leq \pm 0.05$ % of full scale for a min to max supply change.

Load influence: $\leq \pm 0.05$ % of full scale for a 0 to 100 % load resistance change.

Temperature influence: $\leq \pm 0.01$ % on zero and span for a 1 °C change.

Compatibility:

 CE mark compliant, conforms to 94/9/EC Atex Directive and to 89/336/CEE EMC Directive.

Environmental conditions:

Operating: temperature limits -20 to + 60 °C, relative humidity max 90 % non condensing, up to 35 °C.

Storage: temperature limits - 45 to + 80 °C.

Safety Description:



II (1) G [Ex ia] IIC, II (1) D [Ex iaD], I (M2) [Ex ia] I, II 3G Ex nA II T4, [Zone 0] [Ex ia] IIC, [Ex ia] I, [Ex iaD] associated electrical apparatus. $U_o/V_o = 25.2$ V, $I_o/I_{sc} = 93$ mA, $P_o/P_o = 585$ mW at terminals 14-15, 10-11. $U_m = 250$ Vrms, -20 °C $\leq T_a \leq 60$ °C.

Approvals: DMT 01 ATEX E 042 X conforms to EN60079-0, EN60079-11, EN60079-26, EN61241-0, EN61241-11, IECEx BVS 07.0027X conforms to IEC60079-0, IEC60079-11, IEC60079-26, IEC61241-0, IEC61241-11, IMQ 09 ATEX 013 X conforms to EN60079-0, EN60079-15, UL & C-UL E222308 conforms to UL913 (Div.1), UL 60079-0 (General, All Zones), UL60079-11 (Intrinsic Safety "i" Zones 0 & 1) for UL and CSA-C22.2 No.157-92 (Div.1), CSA-E60079-0 (General, All Zones), CSA-E60079-11 (Intrinsic Safety "i" Zones 0 & 1) for C-UL, FM & FM-C No. 3024643, 3029921C, conforms to Class 3600, 3610, 3611, 3810 and C22.2 No.142, C22.2 No.157, C22.2 No.213, E60079-0, E60079-11, E60079-15, Russia according to GOST 12.2.007.0-75, R 51330.0-99, R 51330.10-99 [Exia] IIC X, Ukraine according to GOST 12.2.007.0,22782.0,22782.5 Exia IIC X, TUV Certificate No. C-IS-183645-01, SIL 2 / SIL 3 according to IEC 61508. Please refer to Functional Safety Manual for SIL applications. DNV A-10169, KR ITA20769-EL001 Type Approval Certificate for marine applications.

Mounting: T35 DIN Rail according to EN50022.

Weight: about 170 g D1014D, 115 g D1014S.

Connection: by polarized plug-in disconnect screw terminal blocks to accommodate terminations up to 2.5 mm².

Location: Safe Area/Non Hazardous Locations or Zone 2, Group IIC T4, Class I, Division 2, Groups A, B, C, D Temperature Code T4 and Class I, Zone 2, Group IIC, IIB, IIA T4 installation.

Protection class: IP 20.

Dimensions: Width 22.5 mm, Depth 99 mm, Height 114.5 mm.

Ordering information

Model:	D1014		
1 channel		S	
2 channels		D	
Power Bus enclosure			/B

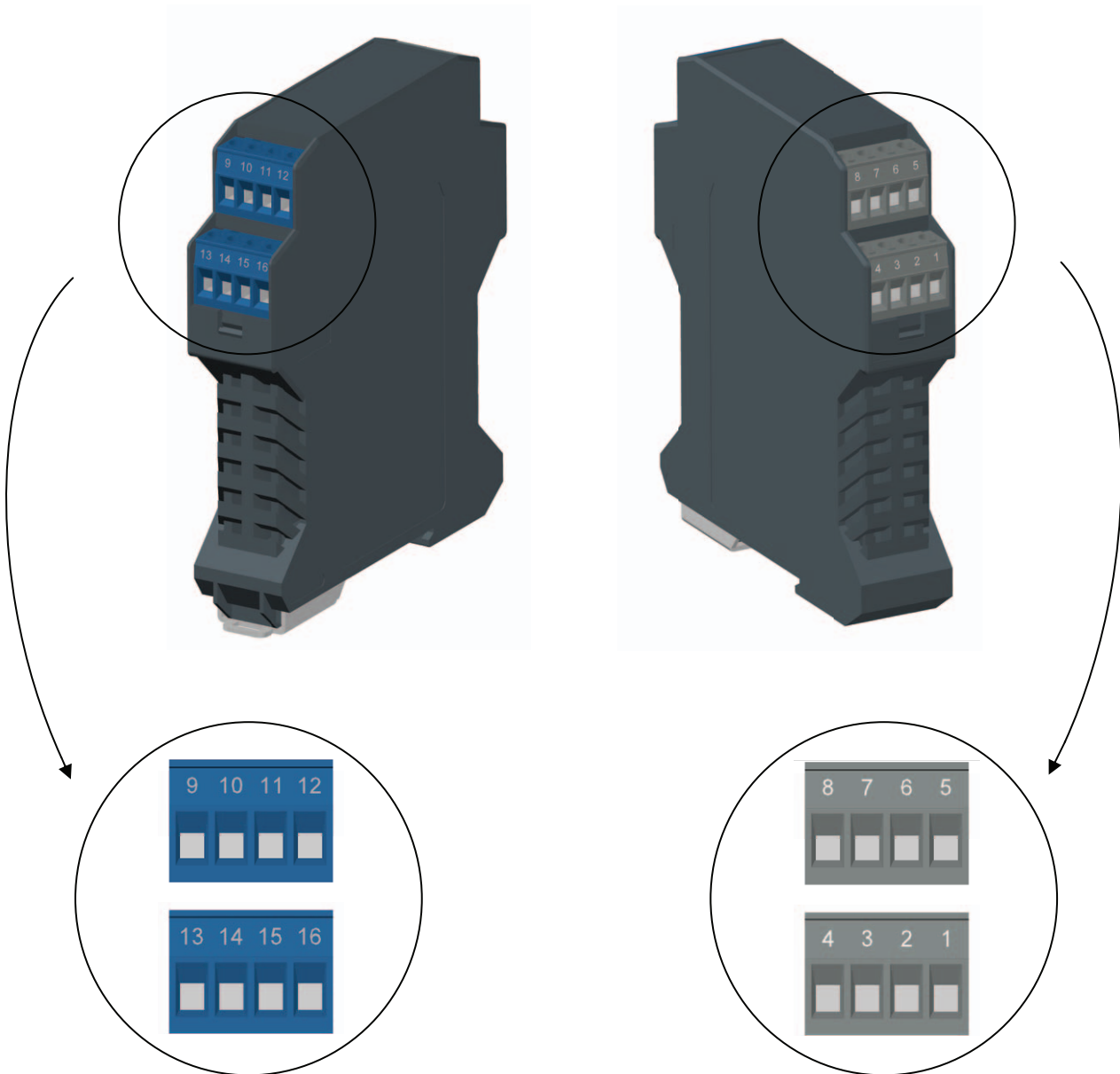

HAZARDOUS AREA

9	Not used
10	+ Input Ch 2 for 2 wire Transmitters
11	- Input Ch 2 for 2 wire Transmitters
12	Not used
13	Not used
14	+ Input Ch 1 for 2 wire Transmitters
15	- Input Ch 1 for 2 wire Transmitters
16	Not used

SAFE AREA

1	+ Output Ch 1 for Current Source mode or + Output Ch 1 for Voltage Source mode or + Output Ch 1 for Current Sink mode
2	- Output Ch 1 for Current Source mode or - Output Ch 1 for Voltage Source mode or - Output Ch 1 for Current Sink mode
3	+ Ch 1 Power Supply 12-24 Vdc
4	- Ch 1 Power Supply 12-24 Vdc
5	+ Output Ch 2 for Current Source mode or + Output Ch 2 for Voltage Source mode or + Output Ch 2 for Current Sink mode
6	- Output Ch 2 for Current Source mode or - Output Ch 2 for Voltage Source mode or - Output Ch 2 for Current Sink mode
7	+ Ch 2 Power Supply 12-24 Vdc
8	- Ch 2 Power Supply 12-24 Vdc

Parameters Table

In the system safety analysis, always check the Hazardous Area/Hazardous Locations devices to conform with the related system documentation, if the device is Intrinsically Safe check its suitability for the Hazardous Area/Hazardous Locations and gas group encountered and that its maximum allowable voltage, current, power (U_i/V_{max} , I_i/I_{max} , P_i/P_o) are not exceeded by the safety parameters (U_o/V_{oc} , I_o/I_{sc} , P_o/P_o) of the D1014 series Associated Apparatus connected to it. Also consider the maximum operating temperature of the field device, check that added connecting cable and field device capacitance and inductance do not exceed the limits (C_o/C_a , L_o/L_a , L_o/R_o) given in the Associated Apparatus parameters for the effective gas group. See parameters on enclosure side and the ones indicated in the table below:

D1014 Terminals		D1014 Associated Apparatus Parameters	Must be	Hazardous Area/ Hazardous Locations Device Parameters
Ch1	14 - 15	$U_o / V_{oc} = 25.2 V$	\leq	U_i / V_{max}
Ch2	10 - 11			
Ch1	14 - 15	$I_o / I_{sc} = 93 mA$	\leq	I_i / I_{max}
Ch2	10 - 11			
Ch1	14 - 15	$P_o / P_o = 585 mW$	\leq	P_i / P_i
Ch2	10 - 11			
D1014 Terminals		D1014 Associated Apparatus Parameters	Must be	Hazardous Area/ Hazardous Locations Device + Cable Parameters
Ch1	14 - 15	$C_o / C_a = 106 nF$ (IIC-A, B) $C_o / C_a = 819 nF$ (IIB-C) $C_o / C_a = 2.899 \mu F$ (IIA-D)	\geq	C_i / C_i device + C cable
Ch2	10 - 11			
Ch1	14 - 15	$L_o / L_a = 4.1 mH$ (IIC-A, B) $L_o / L_a = 16.4 mH$ (IIB-C) $L_o / L_a = 32.9 mH$ (IIA-D)	\geq	L_i / L_i device + L cable
Ch2	10 - 11			
Ch1	14 - 15	$L_o / R_o = 60.7 \mu H/\Omega$ (IIC-A, B) $L_o / R_o = 242.9 \mu H/\Omega$ (IIB-C) $L_o / R_o = 485.8 \mu H/\Omega$ (IIA-D)	\geq	L_i / R_i device and L cable / R cable
Ch2	10 - 11			

NOTE for USA and Canada:
 IIC equal to Gas Groups A, B, C, D, E, F and G
 IIB equal to Gas Groups C, D, E, F and G
 IIA equal to Gas Groups D, E, F and G

For installations in which both the C_i and L_i of the Intrinsically Safe apparatus exceed 1 % of the C_o and L_o parameters of the Associated Apparatus (excluding the cable), then 50 % of C_o and L_o parameters are applicable and shall not be exceeded (50 % of the C_o and L_o become the limits which must include the cable such that C_i device + C cable \leq 50 % of C_o and L_i device + L cable \leq 50 % of L_o). If the cable parameters are unknown, the following value may be used: Capacitance 60pF per foot (180pF per meter), Inductance 0.20 μ H per foot (0.60 μ H per meter).

The Intrinsic Safety Entity Concept allows the interconnection of Intrinsically Safe devices approved with entity parameters not specifically examined in combination as a system when the above conditions are respected. For Division 1 and Zone 0 installations, the configuration of Intrinsically Safe Equipment must be FM approved under Entity Concept, UL Listed or third party approved; for Division 2 installations, the configuration of Intrinsically Safe Equipment must be FM approved under non-incendive field wiring or Entity Concept, UL Listed or third party approved.

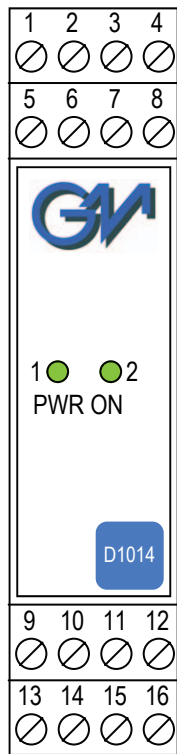

- SIL 3 according to IEC 61508 for $T_{proof} = 1 / 2$ years (10 / 20 % of total SIF).
- SIL 2 according to IEC 61508 for $T_{proof} = 10$ years (10 % of total SIF).
- PFD_{avg} (1 year) 9.91 E-05, SFF 93.48 %.
- 2 fully independent channels.
- Input from Zone 0 (Zone 20), Division 1, installation in Zone 2, Division 2.
- 4-20 mA Input, Output Signal.
- Hart compatible.
- Input and Output short circuit proof.
- High Accuracy.
- Three port isolation, Input/Output/Supply.
- EMC Compatibility to EN61000-6-2, EN61000-6-4.
- In-field programmability by DIP Switch.
- ATEX, IECEx, UL & C-UL, FM & FM-C, Russian and Ukrainian Certifications.
- Type Approval Certificate DNV A-10169, KR ITA20769-EL001 for marine applications.
- High Reliability, SMD components.
- High Density, two channels per unit.
- Simplified installation using standard DIN Rail and plug-in terminal blocks.
- 250 Vrms (U_m) max. voltage allowed to the instruments associated with the barrier.

Function Diagram

HAZARDOUS AREA ZONE 0 (ZONE 20) GROUP IIC,
HAZARDOUS LOCATIONS CLASS I, DIVISION 1, GROUPS A, B, C, D,
CLASS II, DIVISION 1, GROUPS E, F, G, CLASS III, DIVISION 1,
CLASS I, ZONE 0, GROUP IIC

SAFE AREA, ZONE 2 GROUP IIC T4,
NON HAZARDOUS LOCATIONS, CLASS I, DIVISION 2,
GROUPS A, B, C, D T-Code T4, CLASS I, ZONE 2, GROUP IIC T4

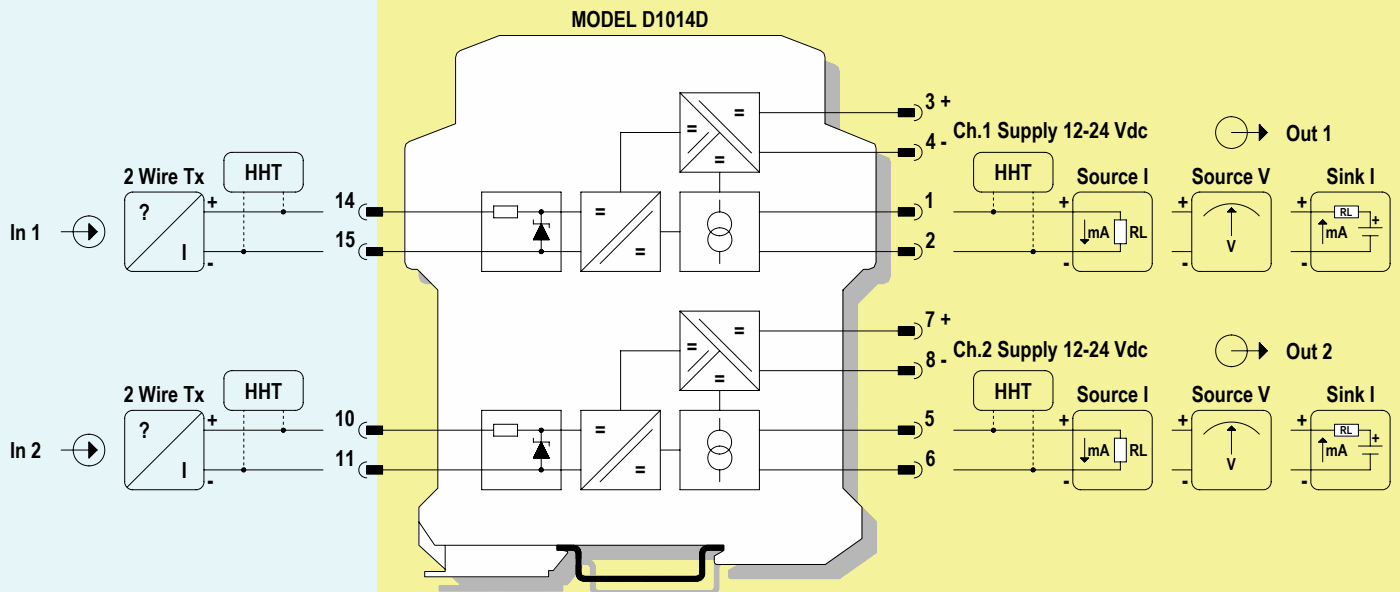

Function Diagram

HAZARDOUS AREA ZONE 0 (ZONE 20) GROUP IIC,
HAZARDOUS LOCATIONS CLASS I, DIVISION 1, GROUPS A, B, C, D,
CLASS II, DIVISION 1, GROUPS E, F, G, CLASS III, DIVISION 1,
CLASS I, ZONE 0, GROUP IIC

SAFE AREA, ZONE 2 GROUP IIC T4,
NON HAZARDOUS LOCATIONS, CLASS I, DIVISION 2,
GROUPS A, B, C, D T-Code T4, CLASS I, ZONE 2, GROUP IIC T4

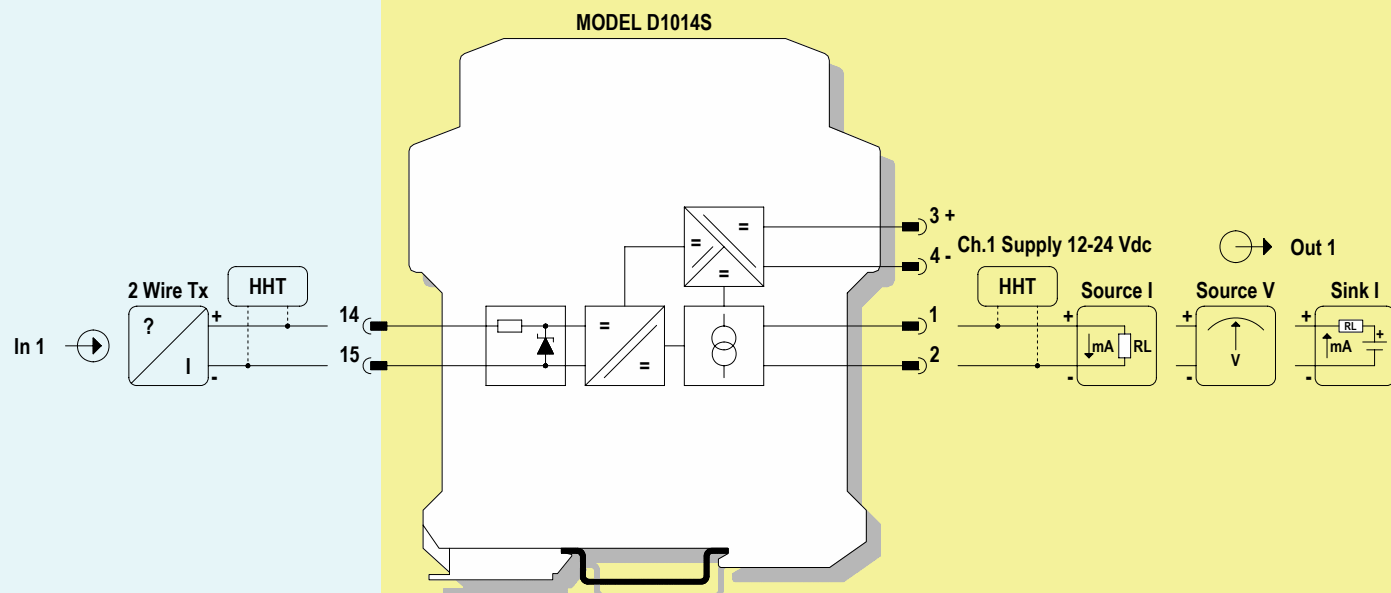

Warning

D1014 series are isolated Intrinsically Safe Associated Apparatus installed into standard EN50022 T35 DIN Rail located in Safe Area/ Non Hazardous Locations or Zone 2, Group IIC, Temperature Classification T4, Class I, Division 2, Groups A, B, C, D, Temperature Code T4 and Class I, Zone 2, Group IIC, IIB, IIA Temperature Code T4 Hazardous Area/Hazardous Locations (according to EN/IEC60079-15, FM Class No. 3611, CSA-C22.2 No. 213-M1987, CSA-E60079-15) within the specified operating temperature limits Tamb -20 to +60 °C, and connected to equipment with a maximum limit for AC power supply Um of 250 Vrms.

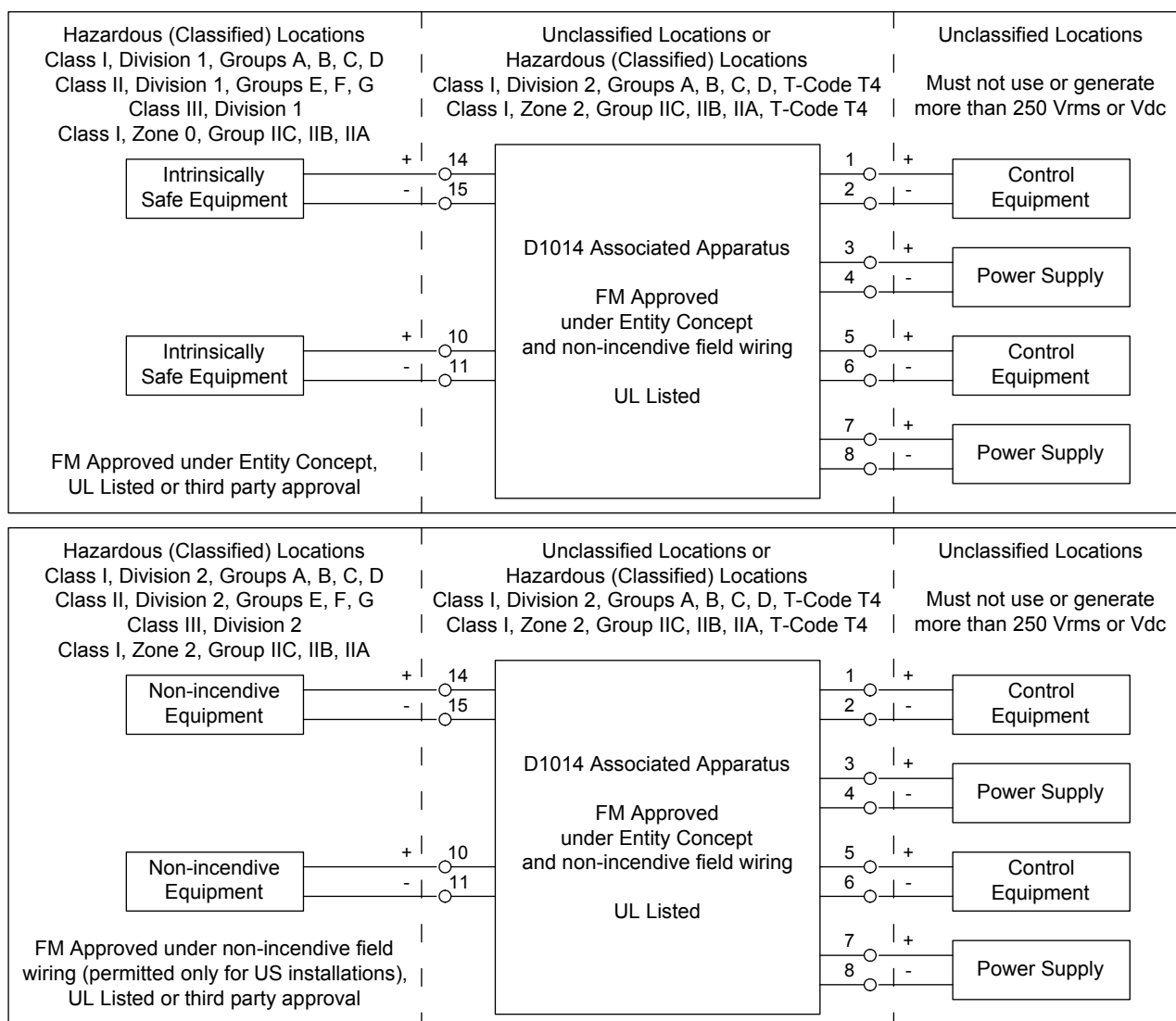

Non-incendive field wiring is not recognized by the Canadian Electrical Code, installation is permitted in the US only.

For installation of the unit in a Class I, Division 2 or Class I, Zone 2 location, the wiring between the control equipment and the D1014 associated apparatus shall be accomplished via conduit connections or another acceptable Division 2, Zone 2 wiring method according to the NEC and the CEC. Not to be connected to control equipment that uses or generates more than 250 Vrms or Vdc with respect to earth ground.

D1014 series must be installed, operated and maintained only by qualified personnel, in accordance to the relevant national/international installation standards (e.g. IEC/EN60079-14 Electrical apparatus for explosive gas atmospheres - Part 14: Electrical installations in hazardous areas (other than mines), BS 5345 Pt4, VDE 165, ANSI/ISA RP12.06.01 Installation of Intrinsically Safe System for Hazardous (Classified) Locations, National Electrical Code NEC ANSI/NFPA 70 Section 504 and 505, and the Canadian Electrical Code CEC) following the established installation rules, particular care shall be given to segregation and clear identification of I.S. conductors from non I.S. ones.

De-energize power source (turn off power supply voltage) before plug or unplug the terminal blocks when installed in Hazardous Area/Hazardous Locations or unless area is known to be nonhazardous.

Warning: substitution of components may impair Intrinsic Safety and suitability for Division 2, Zone 2.

Explosion Hazard: to prevent ignition of flammable or combustible atmospheres, disconnect power before servicing or unless area is known to be nonhazardous.

Failure to properly installation or use of the equipment may risk to damage the unit or severe personal injury.

The unit cannot be repaired by the end user and must be returned to the manufacturer or his authorized representative.

Any unauthorized modification must be avoided.

Operation

D1014 provides fully floating DC supply for energizing 2 wire 4-20 mA transmitters located in Hazardous Area/Hazardous Locations, and repeats and converts the current to a 4-20 mA or 1-5 V floating output signal to drive a Safe Area load. The circuit allows bi-directional communication signal for Hart transmitters. A "POWER ON" green led lits when input power is present.

Installation

D1014 series are repeater power supply hart compatible housed in a plastic enclosure suitable for installation on T35 DIN Rail according to EN50022. D1014 unit can be mounted with any orientation over the entire ambient temperature range, see section "Installation in Cabinet" and "Installation of Electronic Equipments in Cabinet" Instruction Manual D1000 series for detailed instructions.

Electrical connection of conductors up to 2.5 mm² are accommodated by polarized plug-in removable screw terminal blocks which can be plugged in/out into a powered unit without suffering or causing any damage (**for Zone 2 or Division 2 installations check the area to be nonhazardous before servicing**).

The wiring cables have to be proportionate in base to the current and the length of the cable.

On the section "Function Diagram" and enclosure side a block diagram identifies all connections and configuration DIP switches.

Identify the number of channels of the specific card (e.g. D1014S is a single channel model and D1014D is a dual channel model), the function and location of each connection terminal using the wiring diagram on the corresponding section, as an example:

Connect 12-24 Vdc power supply positive at terminal "3" and negative at terminal "4" for channel 1.

For Model D1014D connect 12-24 Vdc power supply positive at terminal "7" and negative at terminal "8" for channel 2.

For Model D1014S connect positive output of channel 1 at terminal "1" and negative output at "2".

For Model D1014D in addition to channel 1 connections above, connect positive output of channel 2 at terminal "5" and negative output at "6".

For Model D1014S connect the wires of input transmitter at terminal "14" for positive and "15" for negative.

For Model D1014D in addition to channel 1 connections above, connect terminal "10" for positive and "11" for negative on channel 2.

Note: terminal "3" and terminal "4" are internally connected to terminal "7" and terminal "8" for factory default. To supply the unit with different supply voltage or different power supply, open the wiring between the terminals (see "Different power Supply" section); consult factory for detailed information. When using Power Bus enclosure the power supply is the same for all channel.

Intrinsically Safe conductors must be identified and segregated from non I.S. and wired in accordance to the relevant national/international installation standards (e.g. EN/IEC60079-14 Electrical apparatus for explosive gas atmospheres - Part 14: Electrical installations in hazardous areas (other than mines), BS 5345 Pt4, VDE 165, ANSI/ISA RP12.06.01 Installation of Intrinsically Safe System for Hazardous (Classified) Locations, National Electrical Code NEC ANSI/NFPA 70 Section 504 and 505, and the Canadian Electrical Code CEC), make sure that conductors are well isolated from each other and do not produce any unintentional connection.

The enclosure provides, according to EN60529, an IP20 minimum degree of mechanical protection (or similar to NEMA Standard 250 type 1) for indoor installation, outdoor installation requires an additional enclosure with higher degree of protection (i.e. IP54 to IP65 or NEMA type 12-13) consistent with the effective operating environment of the specific installation.

Units must be protected against dirt, dust, extreme mechanical (e.g. vibration, impact and shock) and thermal stress, and casual contacts.

If enclosure needs to be cleaned use only a cloth lightly moistened by a mixture of detergent in water.

Electrostatic Hazard: to avoid electrostatic hazard, the enclosure of D1014 must be cleaned only with a damp or antistatic cloth.

Any penetration of cleaning liquid must be avoided to prevent damage to the unit. Any unauthorized card modification must be avoided.

According to EN61010, D1014 series must be connected to SELV or SELV-E supplies.

Start-up

Before powering the unit check that all wires are properly connected, particularly supply conductors and their polarity, input and output wires, also check that Intrinsically Safe conductors and cable trays are segregated (no direct contacts with other non I.S. conductors) and identified either by color coding, preferably blue, or by marking. Check conductors for exposed wires that could touch each other causing dangerous unwanted shorts. Turn on power, the "power on" green led must be lit, for 2 wire transmitter connection the supply voltage on each channel must be ≥ 15 V, output signal should be corresponding to the input from the transmitter. If possible change the transmitter output and check the corresponding Safe Area output.

Configuration

An output configuration DIP Switch is located on component side of pcb. This switch allows the mA (sink or source mode) or Volt operating mode configuration.

Dip switch configuration

Switch positions

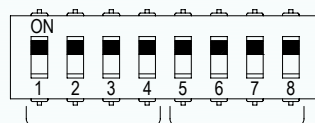

Side A Panel View

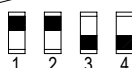
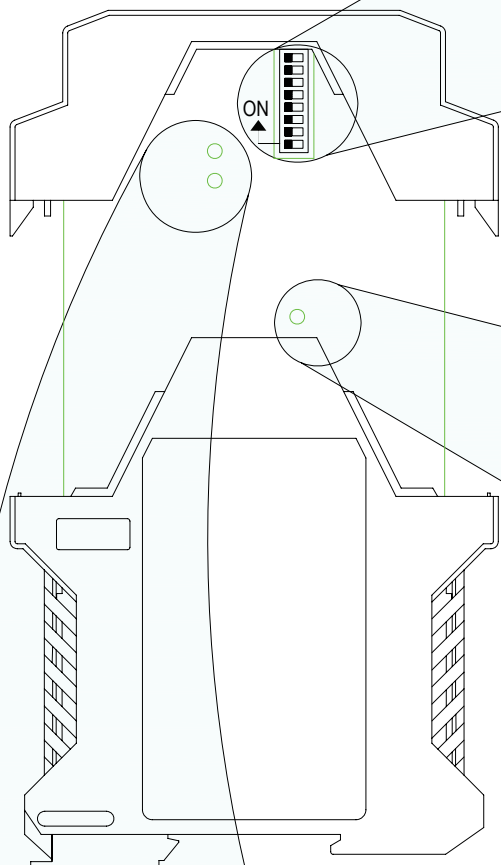

Ch1 4-20 mA
Source Mode

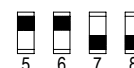

Ch2 4-20 mA
Source Mode



Ch1 4-20 mA
Sink Mode

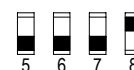

Ch2 4-20 mA
Sink Mode

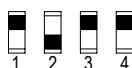

Ch1 1-5 V
(on 250 Ω
internal shunt)

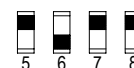

Ch2 1-5 V
(on 250 Ω
internal shunt)

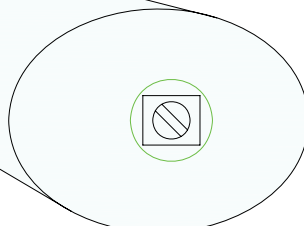

Vtx Adjust Ch1

Screwdriver
for Trimmers
2 x 0.5 mm



Turn the trimmer clockwise to Increase Output value or turn the trimmer counterclockwise if you want to decrease Output value.

Calibration Trimmer Ch1

Span Trimmer
CH1



Zero Trimmer
CH1



Screwdriver
for Trimmers
1 x 0.5 mm



Turn the trimmer clockwise to Increase Output value or turn the trimmer counterclockwise if you want to decrease Output value.

Calibration Trimmer Ch2

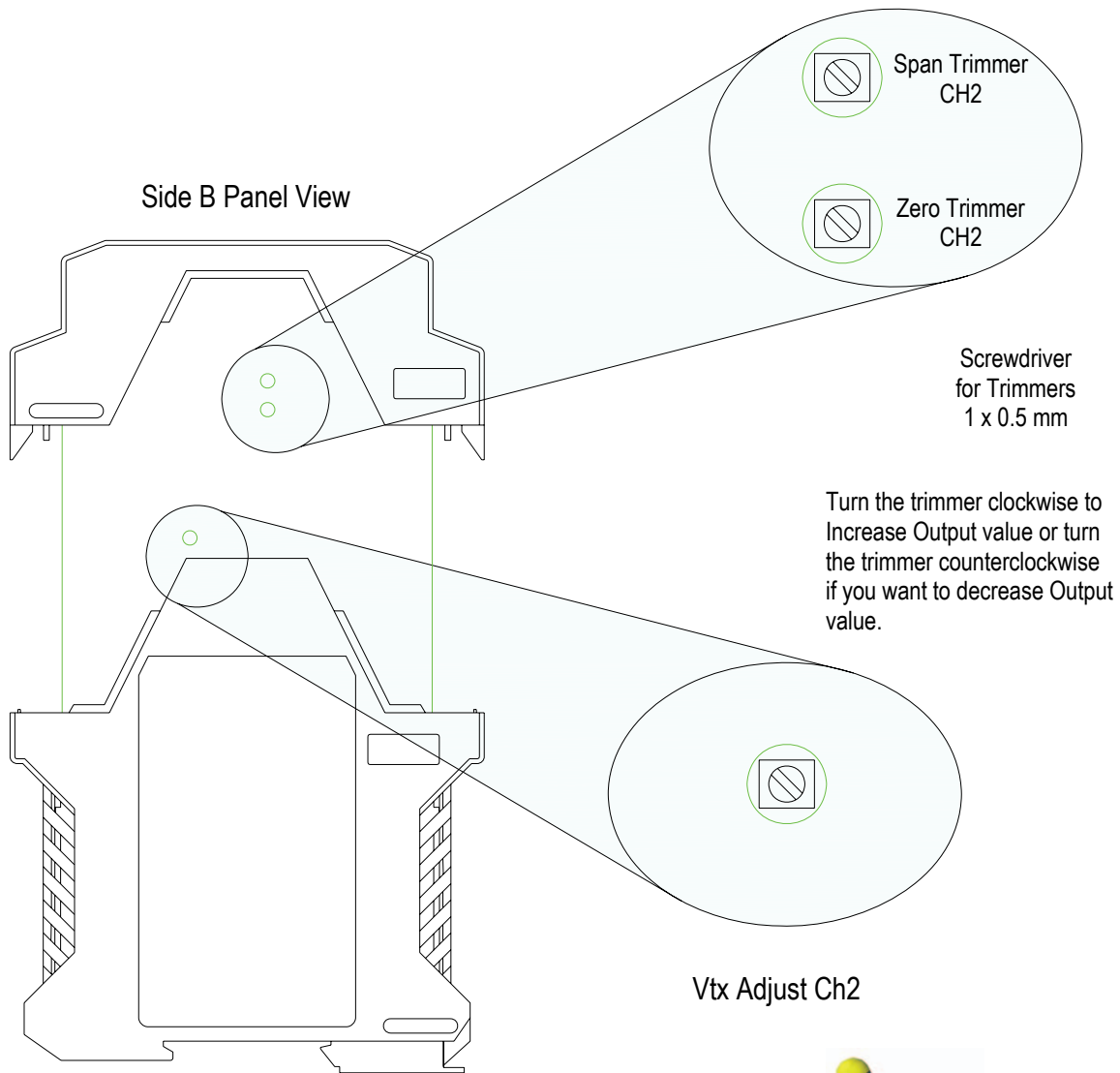

Dip switch Configuration Summary Table

Channel	1				2			
	SW1	SW2	SW3	SW4	SW5	SW6	SW7	SW8
Output Operation	ON	ON	OFF	OFF	ON	ON	OFF	OFF
4-20 mA Source Mode	ON	ON	OFF	OFF	ON	ON	OFF	OFF
4-20 mA Sink Mode	OFF	OFF	OFF	ON	OFF	OFF	OFF	ON
1-5 V (on 250 Ω internal shunt)	ON	OFF	ON	ON	ON	OFF	ON	ON

In case a calibration check or readjustment is necessary the following equipment is required:

Equipment Required	Instrument	Identification
Adjustable Power Supply Range 0-35 V Resolution 0.1 V, Accuracy 1% Output Capability 200 mA	Agilent E3611A	PS
Current Meter range 20 mA, Resolution 1 μ A Accuracy 0.01% or Voltage Meter Range 10 V, Resolution 1 mV Accuracy 0.01%	Agilent 34410A	DMM
Voltage Meter range 30 V, Resolution 1 mV Accuracy 0.05 %	Fluke 175	V1
Current Calibrator range 20 mA, Resolution 1 μ A Accuracy 0.01 %	Yokogawa 7651	CAL

(1) For current output please follow step 1

- Check that dip switch in the unit is in 4-20 mA Source Mode (see “Configuration” section for dip switch position). Connect the unit as shown below:

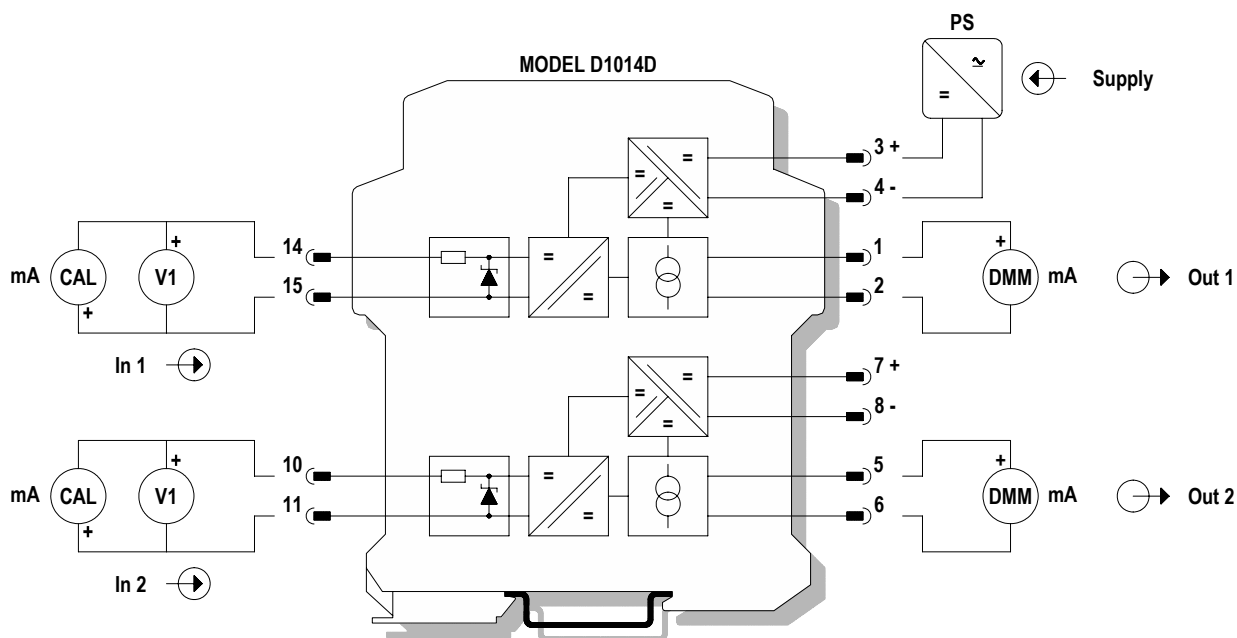

- Set power supply (PS) at 24.0 V at terminals 3 (+) and 4 (-), the calibrator (CAL) in the function “mA” 20 mA range at terminals 14 (-) and 15 (+), the multimeter (V1) for the reading in DC supply 30 V range at terminals 14 (+) and 15 (-), the multimeter (DMM) for the reading in DC supply 20 mA range at terminals 1 (+) and 2 (-).
- Execute the next test to verify D1014S unit channel or execute it twice to verified both D1014D unit channels.
- Verify that green leds on the front panel are ON.

If the power ON Leds are off, check supply voltage, polarity and wiring.

- Set calibrator (CAL) at 20.000 mA and verify that the transmitter voltage, simulated by calibrator (CAL) and read by multimeter (V1), is correspondent at $15.30\text{ V} \pm 0.1\text{ V}$.

If the transmitter voltage is not correct, regulate it by turning the Vtx trimmer of the unit (see “Configuration” section) until reading the correct value.

- Set calibrator (CAL) at 4.000 mA and verify that the output current, read by multimeter (DMM), is correspondent with a maximum deviation presented in the section “Technical Data”.
- Set calibrator (CAL) at 20.000 mA and verify that the output current, read by multimeter (DMM), is correspondent with a maximum deviation presented in the section “Technical Data”.

If the maximum deviation is exceeded, repeat the board calibration and proceed in the following way:

- Set the calibrator (CAL) at 20.000 mA and regulate the current, read by multimeter (DMM), by turning the span trimmer of the unit (see “Configuration” section) until reading $20.000 \text{ mA} \pm 5 \mu\text{A}$ value.
- Set the calibrator (CAL) at 4.000 mA and regulate the current, read by multimeter (DMM), by turning the zero trimmer of the unit (see “Configuration” section) until reading $4.000 \text{ mA} \pm 5 \mu\text{A}$ value.
- Repeat the last two steps to verify that the span trimmer’s movement has not significantly modified the value of zero (a dragging of 1/5 exists when moving span and zero values).
- To execute a linearity test: set the calibrator (CAL) at 4.000, 8.000, 12.000, 16.000, 20.000 mA and verify current output is correspondent with a maximum deviation presented in the section “Technical Data”.

(2) For voltage output please follow step 2

- Check that dip switch in the unit is in 1-5 V mode (see “Configuration” section for dip switch position).
Connect the unit as shown below:

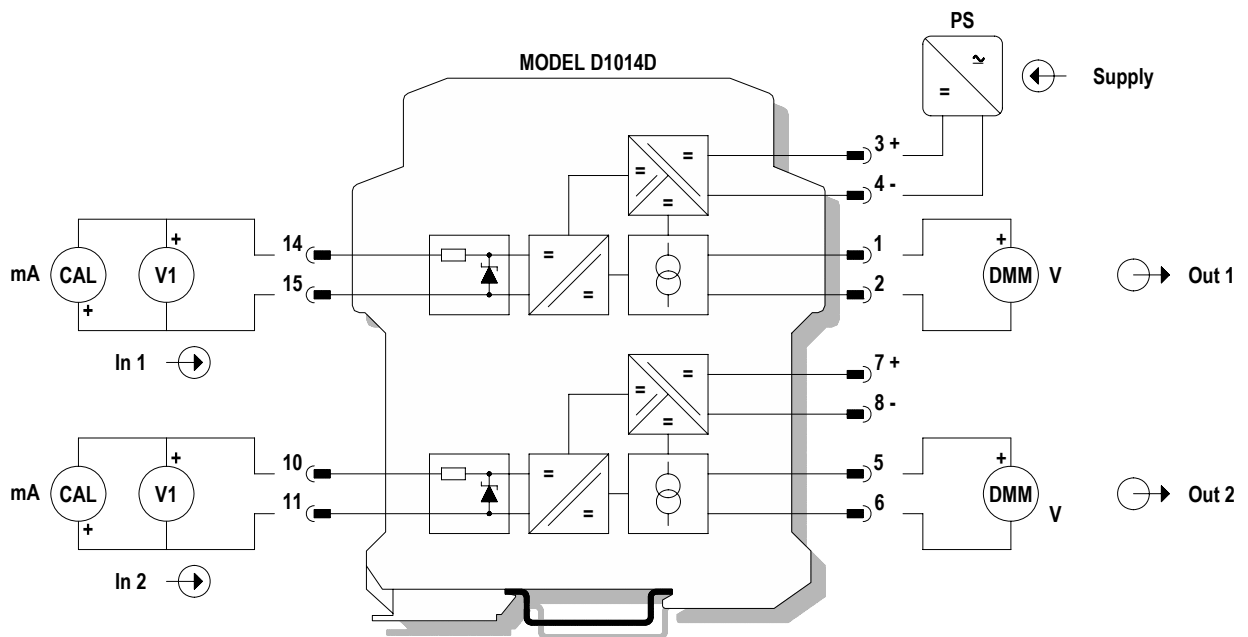

- Set multimeter (DMM) for the reading in DC supply, 10 V range.
- Set calibrator (CAL) at 20.000 mA and power supply (PS) at 9.0 V; verify that output voltage (20 mA current on the 250 Ω shunt resistance) read by multimeter (DMM) is $5.000 \text{ V} \pm 10 \text{ mV}$.

Different power supply

Terminal "3" and terminal "4" are internally connected to terminal "7" and terminal "8" for factory default. To supply the unit with different supply voltage or different power supply, open the wiring between the terminals (see the following figure); consult factory for detailed information. When using Power Bus enclosure the power supply is the same for all channels there for don't separate the terminals because one channel remains switched off.

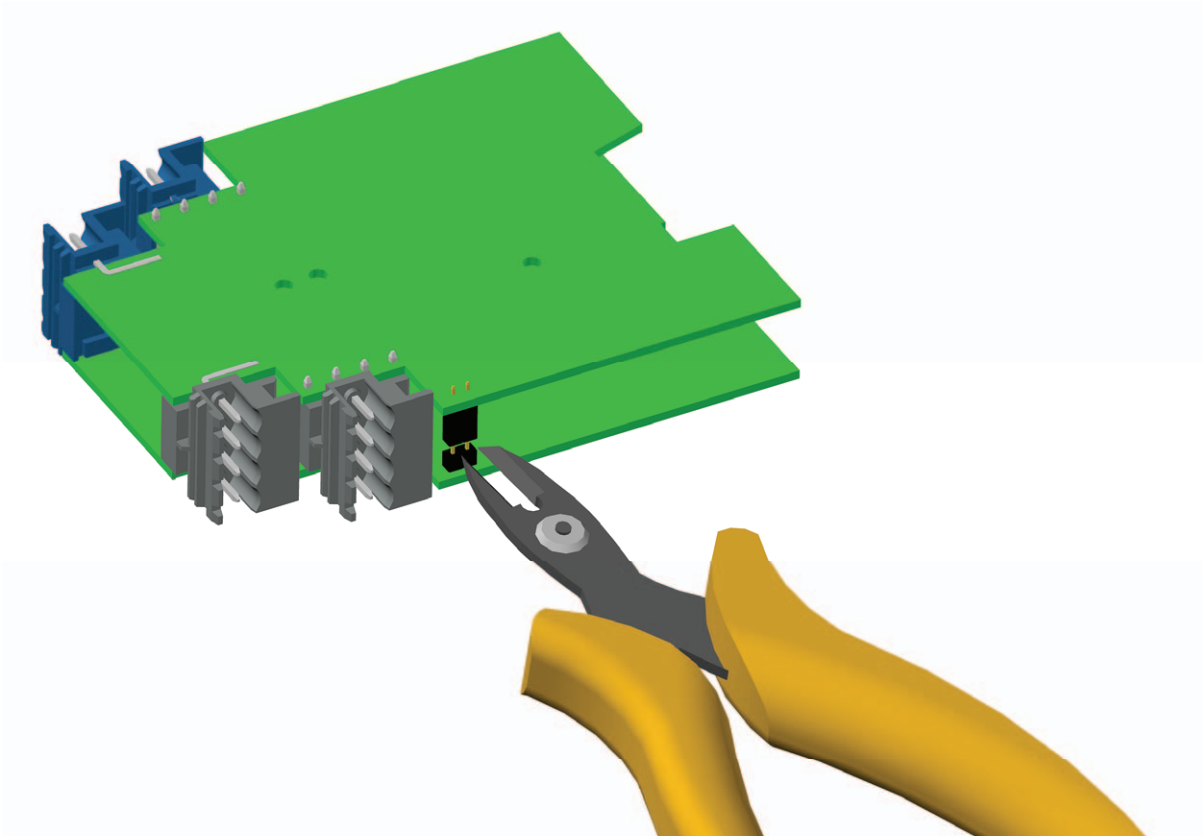

Cut both pins of the connector to open the wiring between the terminals, using a wire cutter

Power Dissipation of D1014 Isolators

Section "Technical Data" of D1014 isolator specifies the current consumption (maximum current from the nominal power supply, typical 24 Vdc, in normal operation); this data serves to dimension the current rating of the power supply unit. Section "Technical Data" indicates also the maximum power consumption (maximum power required from the power supply in the worst (abnormal) operating conditions like for example supply voltage at 30 Vdc, short circuit on the outputs and on the inputs terminals.

The power dissipated P_d inside the enclosure for analog signal isolators is:

$P_d = \text{Current Consumption (A)} * \text{Supply Voltage (V)} - \text{Power Dissipated into the input/output loads}$

Analog signal isolators have higher dissipation than digital signal isolators, in addition 2 channels barriers (D1014D) have higher dissipation than single channel units (D1014S). In analog signal isolators each transmitter requires and dissipates $15\text{ V} * 0.02\text{ A} = 0.3\text{ W}$.

Usually the loads outside the isolator dissipate 1/3 of the total power used.



Isolators are not running at the maximum current all at the same time, the average power consumption of a multitude of isolators can be considered to be only 70 % of the value obtained from the section "Technical Data". Considering the 1/3 load power and the 70 % above discussed, the power effectively dissipated internally by the isolators can therefore become 1/2 of the actual power delivered by the power supply.

Digital barriers dissipate all the supply power inside the enclosure consequently the total power dissipation into a cabinet, with mixed analog and digital barriers, is determined by the number of channels more than by the number of isolator enclosures.

The following tables give advises for the DIN rail orientation (vertical or horizontal) of the barriers mounting, D1014D (double channel) and D1014S (single channel) isolators, installed on DIN rail, bus or custom board assembly.

A) Cabinet with Natural Ventilation

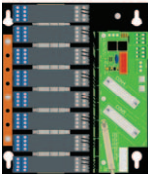
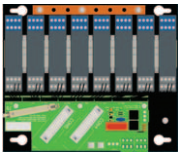

Maximum recommended ambient temperature in °C depending on barrier type and installation method:

Type of Isolator	Single unit Installation	Installation of Multiple units with DIN-rail Bus		Installation on Custom Boards	
	Any orientation	Vertical	Horizontal	Vertical	Horizontal
					
D1014S	60°C	30°C	35°C	35°C	40°C
D1014D	60°C	Not recommended ⁽¹⁾	30°C	30°C	35°C

⁽¹⁾ Installation is not recommended since it would significantly shorten the units life and increase the probability of failures.

B) Cabinet with Forced Ventilation

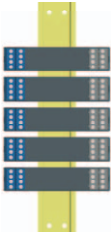
Maximum recommended ambient temperature in °C depending on barrier type and installation method:

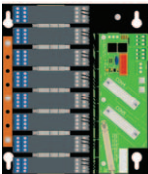
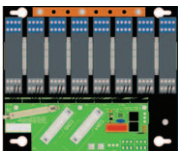
Type of Isolator	Single unit Installation	Installation of Multiple units with DIN-rail Bus		Installation on Custom Boards	
	Any orientation	Vertical	Horizontal	Vertical	Horizontal
					
D1014S	60°C	40°C	45°C	45°C	50°C
D1014D	60°C	40°C	45°C	45°C	50°C